

THE PALIO™

Portable Whirlpool Spa
Owner's Manual

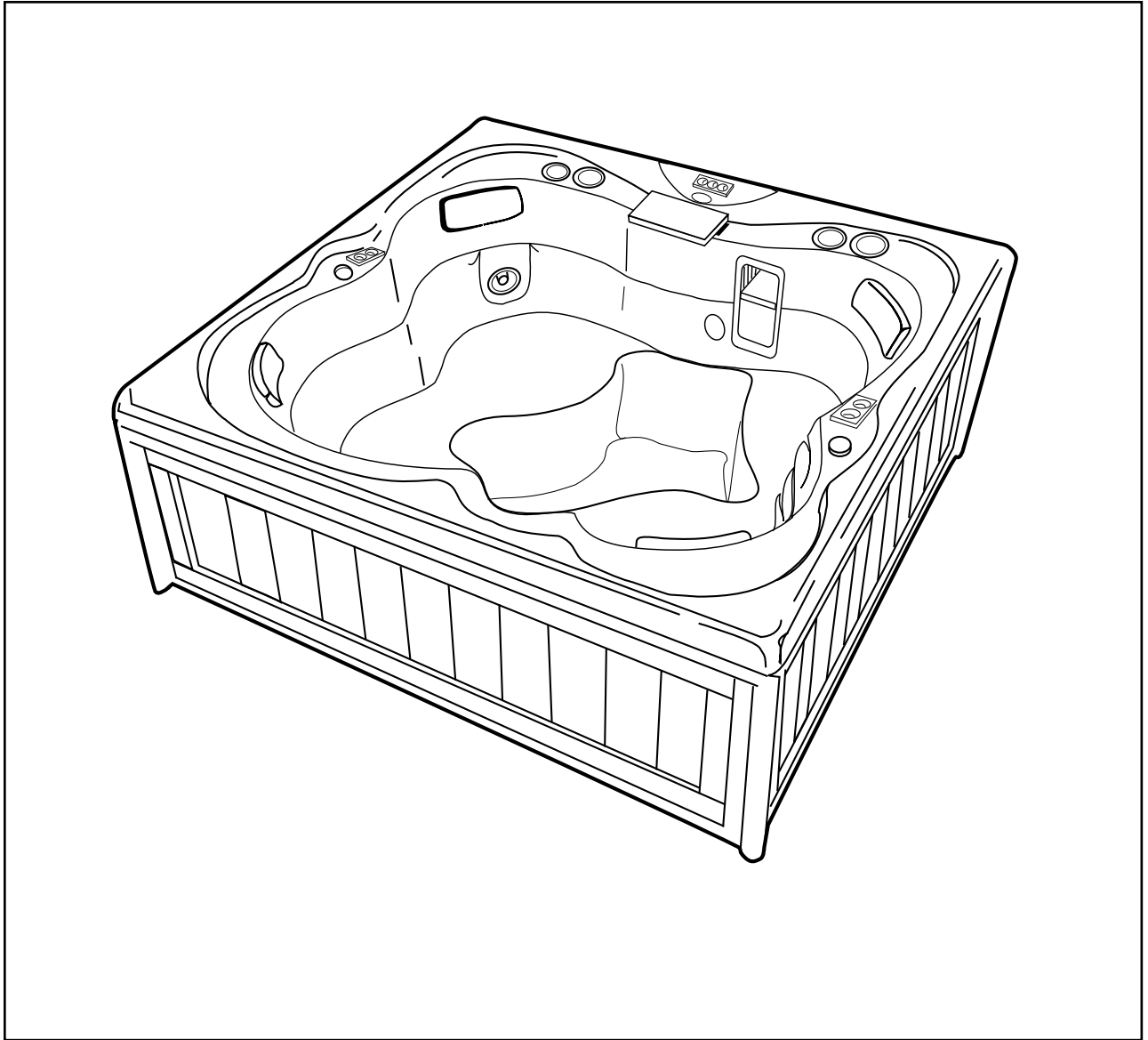

IMPORTANT SAFETY INFORMATION

READ AND FOLLOW ALL INSTRUCTIONS

Jacuzzi Whirlpool Bath does not recommend spa water temperatures in excess of 104° F. High water temperatures in excess of 104° F. and prolonged periods of use can raise internal human body temperature excessively and impair the body's ability to regulate its internal temperature. Limit your initial use of the spa to 10 - 15 minutes. High body temperatures affect people differently; consult your physician about your safety and comfort before using the spa.

The elderly, the infirm, and children should not use the spa unattended. Infants should not be permitted in the spa at water temperatures over 100° F. Pregnant women and people with heart conditions should consult their physicians before using the spa at water temperatures over 100° F.

Extra care should be taken when using the spa and consuming alcoholic beverages. Alcohol, drugs, or certain medications such as tranquilizers affect a person's ability to withstand high temperatures and may produce dangerous effects.

Keep body, hair, and clothing a minimum of 12 inches away from suction fitting and skimmers at all times when the spa is operating. Hair longer than shoulder length should be secured close to the head, or a bathing cap should be worn. Do not remove the suction grille! It is a safety device and must always be in place on the suction fitting to minimize the potential hazard of hair entanglement or body entrapment.

The wet surface of the spa is slippery. Use care when entering and exiting.

The optional cover available for your spa is rigid but is not designed to support any weight. Therefore, as a safety precaution, you must not sit, stand, or lie on it.

The spa must be installed with adequate access and water drainage system. (See Installation Instructions.)

When using the electrical equipment, basic safety precautions should always be followed:

Connect the spa only to a properly grounded receptacle. (See details in Installation Instructions.)

This unit is provided with a ground fault circuit interrupter (GFCI) located in the System Control Module. Check to be sure this is operational at least once a month. (The procedure for testing is described on page 7 of this manual.)

Do not use electrically connected devices such as television, radio, or stereo speakers, lights, cooking devices, or telephones within 5 feet of the spa while the spa is being used. Lighting fixtures must not be located directly above or within 5 feet of the spa. If located within 10 feet of the spa, they must be on a circuit protected by a GFCI.

Do not turn on power to the spa unless it is filled with water to the normal water level, which is to the water level indicator mark on the skimmer frame. Activating the spa when there is an insufficient amount of water can damage the circulation pump and may cause a fire.

Read manufacturer's safety information provided with all optional equipment.

Save These Instructions for Future Use.

Owner's Record

Date Purchased _____

Purchased From _____

Installed By _____ Date _____

Spa Serial Number _____ Model # C600000

(See page 2 for location of number)

The Palio™ Portable Whirlpool Spa

OWNER'S MANUAL

Model C600000

Contents

	Page
Specifications	2
Installation Instructions	2-6
Inspection and Shipping Claim _____	3
Unpacking _____	3
Positioning Your Spa _____	4
Electrical Requirements _____	4
Electrical Precautions _____	5
Outdoor Installation _____	5
Drainage _____	5
Indoor Installations _____	5
Equipment Set-Up _____	6
Operating Instructions	7-11
Basic Control Set-Up _____	7
Setting the Timer _____	8
Controls _____	9
Temperature Control _____	10
Setting the Thermostat _____	10
Note on Determining Water Temperature _____	10
Normal Operation _____	11
Whirlpool System _____	11
Water Rainbow _____	11
Air Blower _____	11
Silent Air Induction _____	11
Filtration _____	11
Maintenance	12-16
Water Quality and Water Chemistry _____	12
Filtration _____	12
Water Chemistry _____	12
Disinfecting _____	13
Balancing pH _____	13
Balancing Total Alkalinity _____	13
Water Quality Definitions _____	13
Water Level/Drain _____	14
Skimmer Basket Maintenance _____	14
Filter Maintenance _____	14
Automatic Filtration/Maintenance _____	15
Winterizing _____	15
Factory Installed Redwood Skirt _____	15
Spa Light _____	16
Covering Your Spa _____	16
Cleaning Your Spa _____	16
Repairs to the Acrylic _____	16
Troubleshooting Guide	17-19
Alternate Use for Water Rainbow _____	20

The Palio™ Portable Whirlpool Spa Specifications and Installation Instructions

The Palio™, a portable whirlpool spa by Jacuzzi Whirlpool Bath -is the ultimate in beauty, comfort, and convenience. Its elegantly sculptured contour seating for four, and strategically located, PowerPro™ adjustable whirlpool jets will provide you with the total luxury of the hydromassage performance for which Jacuzzi Whirlpool Bath is famous. The Palio offers the convenience of the patented front-load skimmer/filter, an advanced feature design by Jacuzzi Whirlpool Bath to allow easy access to the filter cartridge without having to drain the spa or open the skirt door. The Palio also comes complete with integrated heater, silent air induction, low voltage underwater light with interchangeable colored lens filters, whirlpool system, and air blower and factory drilled air holes. The spa shell is insulated to save energy costs and is surrounded by a factory installed redwood skirt.

A standard feature of the Palio is the Water Rainbow™ spout with flow control, with will create a dazzling, shimmering cascade effect while recirculating the water. A clearly labeled control panel allows convenient control of heating, filtration, whirlpool, light and air blower functions from inside or outside the spa. A 7-day timer (located on the System Control Module) can be set for automatic control of temperature and filtration.

Compact and portable, the Palio is easy to install. It requires a 115 VAC 20 AMP, grounded separate circuit and is equipped with a Ground Fault Circuit Interrupter (GFCI). The equipment pack of the Palio is mounted with the perimeter of the shell. An optional gas heater is available as an alternate heating source and can be installed remotely. To protect the spa from debris and reduce heat loss, a rigid insulating spa cover is available as an option. The Palio is available in several lustrous acrylic colors with color-coordinated fittings. (See the Jacuzzi Whirlpool Bath Color Guide.)

OPTIONS

- Gas Heater
- Electric Heater
- Rigid Insulating Cover

SPECIFICATIONS

MODEL	DIMENSIONS	WHIRLPOOL MOTOR/ PUMP(2)	FLOOR LOADING	OPERATING GALLONAGE	ELECTRIC HEATER	SHIPPING WEIGHT	ELECTRICAL REQUIREMENTS
Palio (C600000)	72" L. (1829 mm) 66" W. (1676 mm) 30" H. (762 mm)	1.0 HP, 2 speed (.6 Kw) 115 VAC 3.5/11.5 AMPS 1725/3450 RPM Single Phase 60 Hz.	76 lbs./sq. ft. (371.7 kg./sq.m.) Total Weight: 2558 lbs. (1163 kg.)	190 US Gal. (719 Ltrs.)	1.5 Kw 11.5 AMPS	525 lbs. (238.6 kg.)	115 VAC* 20 AMP 60 Hz. Separate Circuit (See Page 4)

* May be field converted to 230 VAC.

PRODUCT SPECIFICATIONS ARE SUBJECT TO CHANGE WITHOUT NOTICE.

TOP VIEW

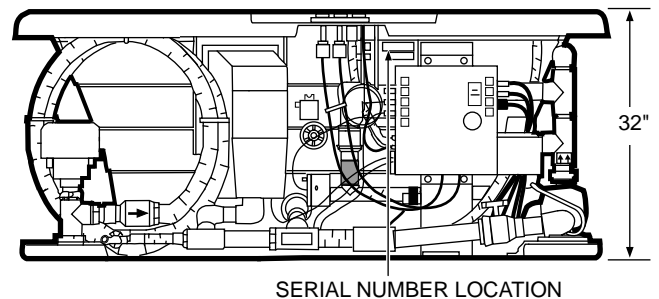
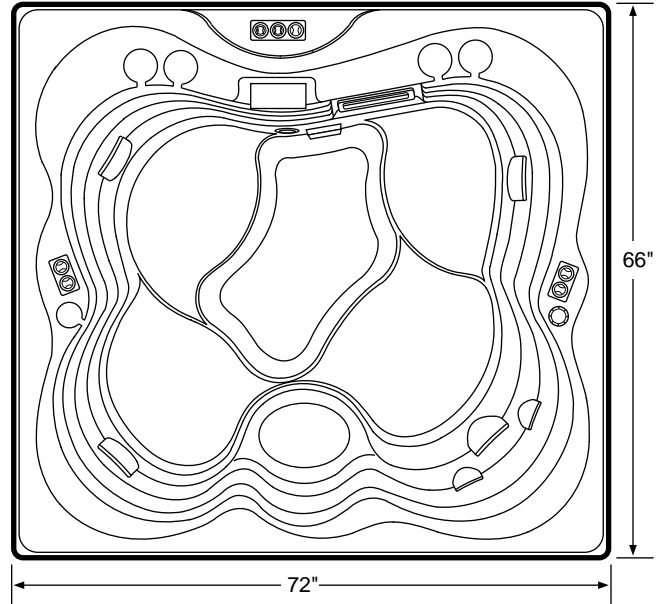

SIDE VIEW

ARCHITECTURAL SPECIFICATION

(short Form)

Whirlpool spa shall be the Palio™ whirlpool spa as manufactured by Jacuzzi Whirlpool Bath in colors and sizes shown in drawings and schedules.

INSTALLATION

Installation Instructions

Inspection and Shipping Claim

Check for shipping damage upon receipt of the spa. Jacuzzi Whirlpool Bath is not responsible for damage to the spa sustained during shipping. If damage is evident before unpacking, see instructions regarding shipping claims on the outside of the carton and immediately file a claim with the carrier.

Once the spa has been removed from the carton and before it is permanently installed (see below on this page for unpacking instructions), check the spa completely for damage. Fill the shell with water and operate the system (see Operating Instructions) to check for leaks which may have resulted from shipping or handling. All Jacuzzi Whirlpool Bath spas are factory tested for proper operation and water tight connections prior to shipping. If leaks or other problems are detected, immediately notify your Jacuzzi Whirlpool Bath dealer or Authorized Service Agent, or call Jacuzzi Whirlpool Bath, (510) 938-7411, or (510) 938-7070 for Warranty Service.

Note: Damage or defects which could have been discovered and repaired prior to installation and which are claimed after final installation of the spa, are excluded from our warranty.

Unpacking

1. Remove the outer carton by cutting the bands and lifting the cover and the sides. Leave the protective plastic sheet on the spa until installation begins. This sheet can be re-used to protect the finish from damage and debris during construction.
2. Lift the spa from the carton (approximate weight 450 lbs.) and set it in place on the patio, deck, or position of intended use. **Do not handle the spa by its plumbing; handle it by the bottom of the skirt only.**
3. If, after having been removed from the carton, the spa must be turned over onto its side to move, make sure the surface of the cart or dolly on which it is placed is large enough to support the product weight and could be damaged if allowed to do so. (See illustration on this page, lower right.)

Before installation begins, remove the owner's packet from the Accessory package. This package contains the Warranty Card and the Owner's Manual. Record the spa serial number on the inside front cover of this manual and on the warranty card. (See the illustration on page 2 for the serial number location.)

Important: Read complete instructions before beginning installation.

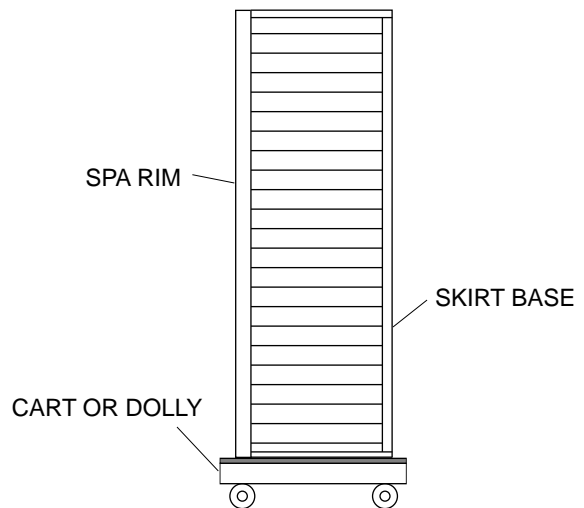
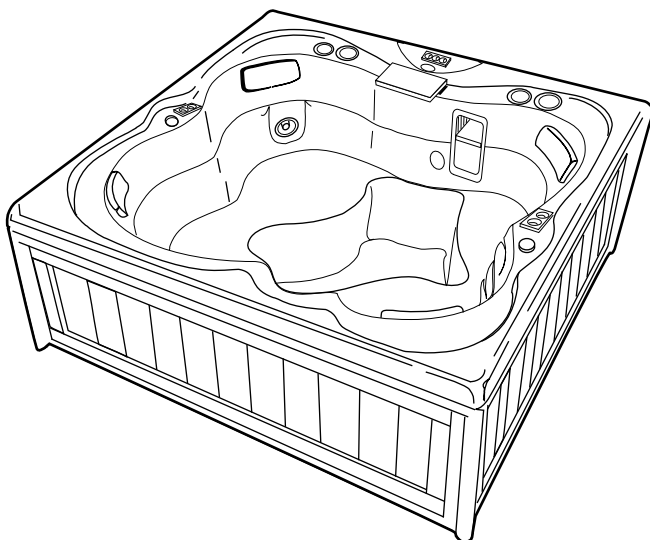
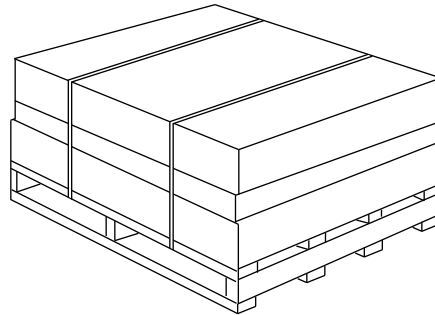

SURFACE MUST SUPPORT SPA RIM AND BASE OF SKIRT

INSTALLATION

Positioning Your Spa

Because your Palio™ spa is portable, you can locate it just about anywhere you wish—on a deck, patio, or even indoors. Just be sure to position it above ground in an area with good drainage and on a level, continuous surface which can support the weight of the spa when filled with water and people; this weight is approximately 2558 lbs. (76 lbs. per square foot). You must also provide access to the spa's equipment for service and general maintenance.

Electrical Requirements

Your Palio™, as it comes from the factory, requires a 115 VAC 20 AMP 3-wire grounded type electrical service with copper conductors and must be in a separate circuit having no other appliance connected in that circuit. If you do not have this kind of circuit, a qualified electrician should be called in to install the necessary wiring. Inadequately sized wiring may cause a voltage drop which might cause the unit to malfunction and bring about permanent damage to the spa's electrical system. The circuit must also have a ground wire in order to take advantage of the designed-in safety features of the spa. A bond wire must also be used. Bond according to procedure described on the next page.

Caution: Without proper grounding and bonding, a system malfunction may cause fatal shock.

To increase the heating capability of your spa's heater and convert the output from 1.5kw to 6.0kw (23 amps), your spa can be hard-wired on-site in approved conduit (or with approved power cable) to operate at 230 VAC 50 AMPS. This requires a separate circuit which will not be shared by any other appliance. We recommend that this re-wiring be done by a qualified electrician. A wiring diagram and re-wiring instructions are provided on the inside of the junction box mounted to the System Control Module. When this conversion to 230 VAC has been made, any combination of operating modes is possible, including having the heater on when the whirlpool mode is activated. Also, the heat-up rate will be approximately four times greater.

Electrical Safety Precautions

1. Palio is supplied with a 15 ft. power cord which terminates with molded plug. Locate the spa near enough to a weather protected outlet, but no closer than 10 ft. **DO NOT USE EXTENSION CORD!** Using an extension cord is hazardous and will decrease the amount of power to the unit, causing slow heating, poor whirlpool performance, or system malfunction.

Bring the power cord out from under the skirt at one of the front corners. Make sure the power cord does not lie across a walk way or in a heavily traveled area where it may be a safety hazard or become damaged.
3. Do not locate lighting fixtures directly above the spa; lighting and electrical receptacles must be located at least 5 ft. from the spa. Lighting located between 5 and 10 ft. from the spa must be on a circuit protected by a GFCI. (See National Electrical Code, 680-6.)

Do not use electrically connected devices, such as television, radio, toys, telephones, stereo speakers, lights or cooking devices within 5 ft. of the spa when the spa is being used.

CAUTION

Do not apply electrical power to the spa unless it is filled with water to the normal water level, which is approx. 6" below the spa rim (see location of water level indicator on face of skimmer on page 6). If the spa's motor/pumps are actuated when there is not sufficient water in the unit, the circulation pump could be irreparably damaged. Not heeding this caution will nullify the warranty. In addition to damaging the unit, operating the unit with insufficient water could cause a fire.

SERVICE ACCESS

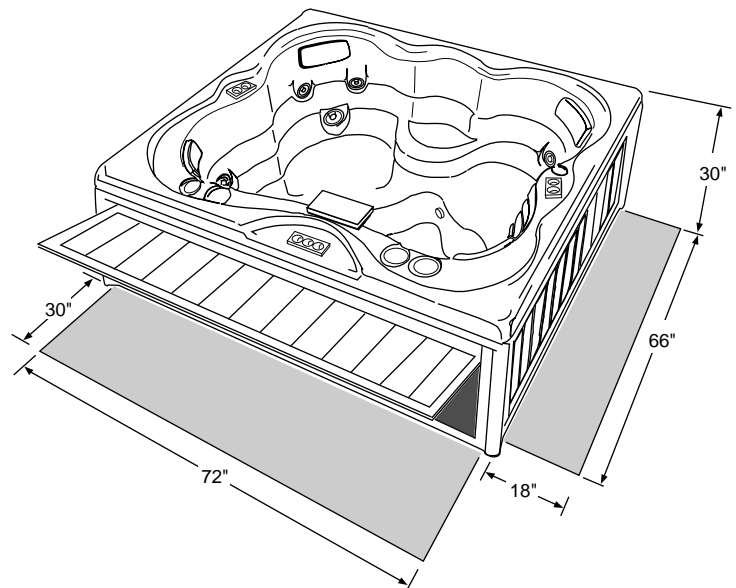

INSTALLATION

Electrical Precautions (Continued)

3. All fixed metal objects located within 5 ft. of the spa, such as fence posts, railing, greenhouse structures, gutters, etc., must be attached to the bonding on the outside of the spa electrical cabinet using #8 solid copper wire. **With #8 solid copper wire, bond the spa to the house electrical panel or local bond, (Bond bar location is shown on page 5.)**
4. **An approved ground may be an 8ft. long ground rod, a plate electrode, or a buried metal water pipe with at least 10 ft. of buried pipe. Check your local building code for requirements. Bonding lugs are available at your local electrical supply store.**

WARNING!

The continuous service ground wire is located in the power cord supplied. **Do not modify this cord in any way!** Tampering with the ground wire or using an adapter which would make the built-in grounding device and GFCI ineffective would cause electrical shock. Such modification would also nullify the warranty.

Outdoor Installation

If you install the spa outdoors, we recommend that you provide a concrete pad for it to rest on. To do this, construct forms for a 8' x 8' x 4" thick level pad. Install a #10 gauge wire mesh 6" x 6" steel reinforced grid. Attach a #8 solid copper wire to the grid with a ground clamp. This wire should be long enough to reach the bond bar on the spa electrical cabinet (min. 36"), but should not be located under the base of the spa. Then pour the concrete pad.

Drainage

Whether you install your spa indoors or outdoors, you can drain it almost completely by attaching a garden hose to the drain valve located on the suction tee of the spa. Simply run the hose to the house sewer line or drain field and open the drain valve.

Make sure the area surrounding the spa has good drainage to keep water from collecting at the base of the spa—especially near the equipment area. If drainage is poor, install a drain line and/or gravel drain field (see illustration below).

Indoor Installations

Water which splashes on the floor during use of the spa may cause a walking hazard and/or structural damage unless good drainage is provided and proper waterproof building materials are used in the area surrounding and beneath the spa. Take into consideration, also, the high room humidity which will exist due to high spa water temperatures. Providing natural or forced ventilation of the room will help maintain comfort and minimize moisture damage to the building. Jacuzzi Whirlpool Bath is not responsible for damages resulting from excess moisture or water spillage. Consult an architect or engineer for aid in designing your indoor installation. Note: If you install your spa on a carpeted surface, place a 1/2" - 3/4" sheet of plywood between the carpet and the bottom of the spa. This will restore the airspace under the spa required for proper motor ventilation and cooling.

SUPPORT AND DRAINAGE

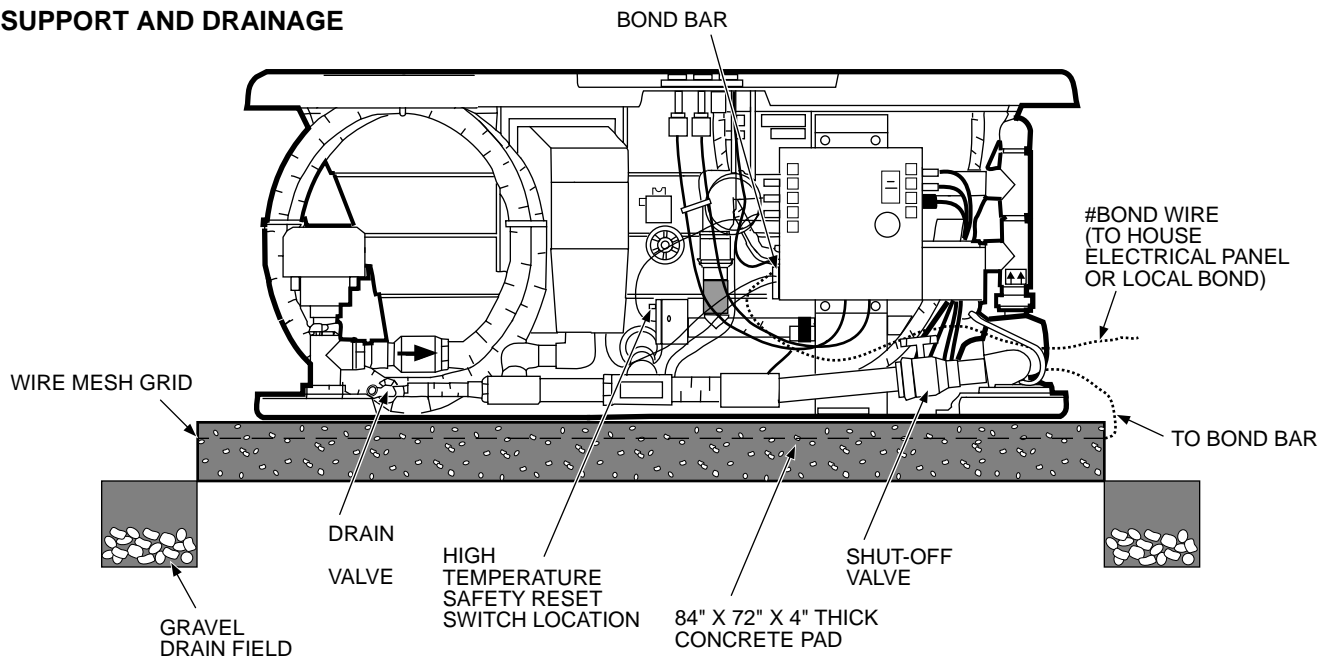

INSTALLATION

Equipment Set-Up

1. Remove the plastic sheet covering the spa. Use care; stepping into the spa with shoes will scratch the acrylic surface.
2. Remove any packing materials from the spa.
3. Remove each filter cartridge from its plastic bag.
4. Pull open each skimmer/filter door by the handle located in the middle of the door and remove the skimmer basket. Then insert the filter cartridge into the filter housing and re-insert the strainer so that it fits in place over the filter cartridge and close the skimmer/filter door.
5. Clean the interior of the spa of any remaining construction debris. Remove stubborn stains, paint, or tar with turpentine, isopropyl alcohol or paint thinner. A mild liquid dishwashing detergent on a damp cloth is fine for cleaning off other dirt. Plaster can be removed by scraping with a wooden edge; do not use a metal scraper, wire brush, or other metal tools, as they will damage the spa's surface
6. On initial start-up, it is necessary to purge and sanitize the system. Carefully follow the procedure described here to purge and sanitize your spa.
7. Open the redwood skirt door. (Locate latches at each end of door and loosen by hand or with flat blade screwdriver.)
 - Open shut-off valve located in suction line.
 - Close the hose bibb located on the suction tee.
 - Fill the spa with water to its normal operating level, which is to the water level indicator mark on the skimmer/filter frame.
 - Close redwood skirt door.
 - Plug the power cord into the proper receptacle in a 115 VAC 20 AMP circuit.
 - Select JETS on the SYSTEM switch.
8. Add 1/4 cup sodium dichlor (a fast dissolving granular type of chlorine) to the water and let the whirlpool run for 15-20 minutes only.
9. To purge and sanitize the air blower piping as well, operate the air blower twice at 15 minute intervals alternating with the whirlpool system.
10. Turn off the whirlpool.
11. Unplug the power cord.
12. Open redwood skirt door.
13. **Immediately open the hose bibb and drain the spa.** Connect a garden hose to the hose bibb on the suction tee. Turn the handle and drain the spa.

CAUTION: Leave the optional rigid cover off the spa during this procedure. Do not use the spa during this procedure. Drain the spa immediately afterward.

8. Close the drain valve and fill the spa with water to approx. 6 inches below the spa rim, or to water line indicator mark on the skimmer frame. (See illustration on this page.)
9. Plug in the power cord.
10. Set the heater thermostat for the maximum temperature.
11. Test the spa for proper operation. (Refer to Operating Instructions.)
12. Refer to Water Quality section of the Operating Instructions. Test for water quality; then add treatment chemicals to ensure proper levels.

All Jacuzzi Whirlpool Bath spas are factory tested for proper operation and water tight connections prior to shipping. If leaks or other malfunctions are detected, immediately notify your Jacuzzi Whirlpool Bath dealer or Authorized Service Agent, or call Jacuzzi Whirlpool Bath, (510) 938-7411 (510) 938-7070 in California), for Warranty Service.

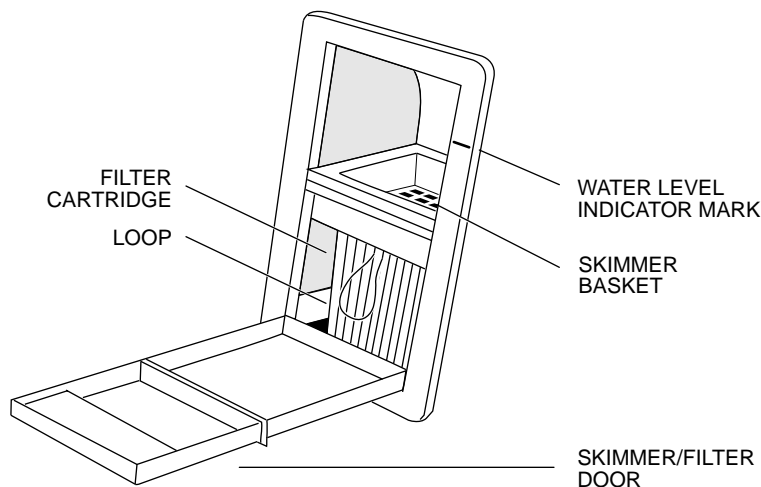

OPERATION

Operating Instructions

Now that your Palio spa is in place, you are probably eager to take advantage of its unique designed-in features—especially the patented Jacuzzi Whirlpool Bath hydromassage performance. Besides being a beautiful addition to your indoor decor or outdoor landscaping, your Jacuzzi whirlpool spa will provide you with the ultimate in spa pleasure.

Basic Control Set-Up

The control set-up on your Palio spa is designed to give you fingertip control of the heater, air induction, light and whirlpool, filter, and blower systems of your unit from inside or outside your spa. Follow the basic control set-up described below to familiarize yourself with the several functions of the control panels located on the top of the spa.

CAUTION: Do not turn on power to the spa unless it is filled with water to the normal water level. (See water line indicator mark on skimmer frame.) When the power is on, the built-in timer may activate the system even though the SYSTEM is turned off at the control panel. If the spa's motor/pump is actuated when there is not sufficient water in the unit, the circulation pump and heater could be irreparably damaged. Not heeding this caution will nullify the warranty. In addition to damaging the unit, operating the spa with insufficient water could cause a fire.

- Using a garden hose, fill the spa with water to the water line indicator mark on the skimmer frame.
 - At the house service panel, turn on the circuit breaker or switch that controls the electrical service to your spa. (Make sure there is no other appliance on that circuit.)
 - Open the skirt door giving access to the System Control Module.
- Your spa is provided with a ground fault circuit interrupter (GFCI). At initial start-up and at least once a month thereafter, with power on, push the test button located on the System Control Module. The reset button should pop out. Push this button in to reset. If the interrupter fails to operate in this manner, there is a ground current flowing or a device malfunctioning, indicating the possibility of electric shock. **Turn off power and do not use the spa until the source of the breakdown has been identified and corrected.**
- Locate the HIGH TEMPERATURE SAFETY SWITCH, which is a raised button on the end of the heater. Push this button to be sure it is in the reset mode. The purpose of this switch is to shut down the spa if the water becomes excessively hot. If, for some reason, the switch is tripped, the reset button must be pushed in for the heater to operate again after the water has cooled to about 90°F.
 - Set the built-in timer (see below). Use of the timer allows two modes of operation: timed HTR/FLTR and timed FILTER ONLY. With the SYSTEM switch turned OFF and the HEATER knob set to the desired temperature, the timer will activate the heater and filter pump to operate during the time period set on the timer. With the SYSTEM switch turned OFF and the HEATER knob turned to its lowest setting, the water will be filtered and the water temperature will be maintained at the minimum temperature (approx. 50 degrees) during the time period set on the timer.
 - Close and latch the redwood skirt door.
- Make sure the circuit protector buttons are pushed in.

SYSTEM CONTROL MODULE

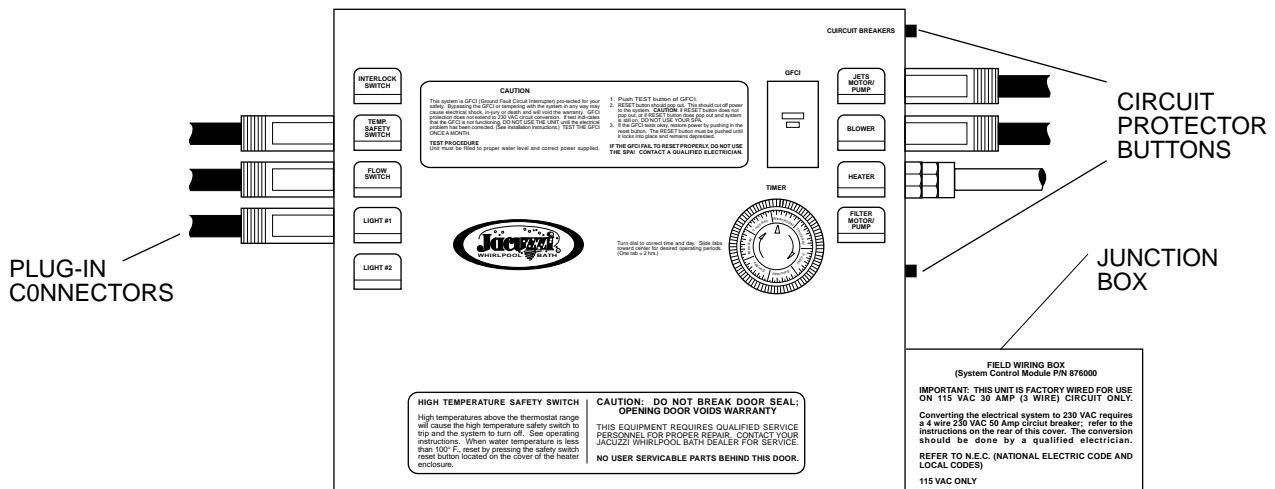

OPERATION

Controls

A switch panel giving you convenient control of the JETS, FILTER, HTR/FLTR, light and air blower is located on the spa rim.

To ensure your safety and allow easy operation, your spa is equipped with two air-activated switches. One, the SYSTEM switch, controls the whirlpool jets, heat, and filtration. The other switch, ACCESSORY controls the air blower and optional light.

Refer to the Control Panel illustration for an explanation of the various switch functions.

SYSTEM

The SYSTEM switch controls the following four functions in the continuous sequence indicated:

1. OFF
2. JETS
3. HTR/FLTR
4. FILTER

(The next selection is OFF again.)

Use the JETS function as a reference to indicate your location in the function sequence, since that function is the most obvious when operating.

For best performance and increased equipment life, pause a second or two between push-button selections. Not pausing may cause the switch to malfunction.

ACCESSORY

The ACCESSORY switch controls these functions in the continuous sequence indicated:

1. OFF
2. AIR/LIGHT
3. AIR
4. LIGHT

When the AIR (blower) function is activated, the jets will turn off if they have also been selected by the SYSTEM switch. Activating the AIR function will also turn off the heater if the HTR/FLTR function has been activated by the SYSTEM switch. (If the unit is properly converted to operate at 230 VAC 50 AMP, 4-wire, no overriding of features will exist.)

CONTROL PANEL

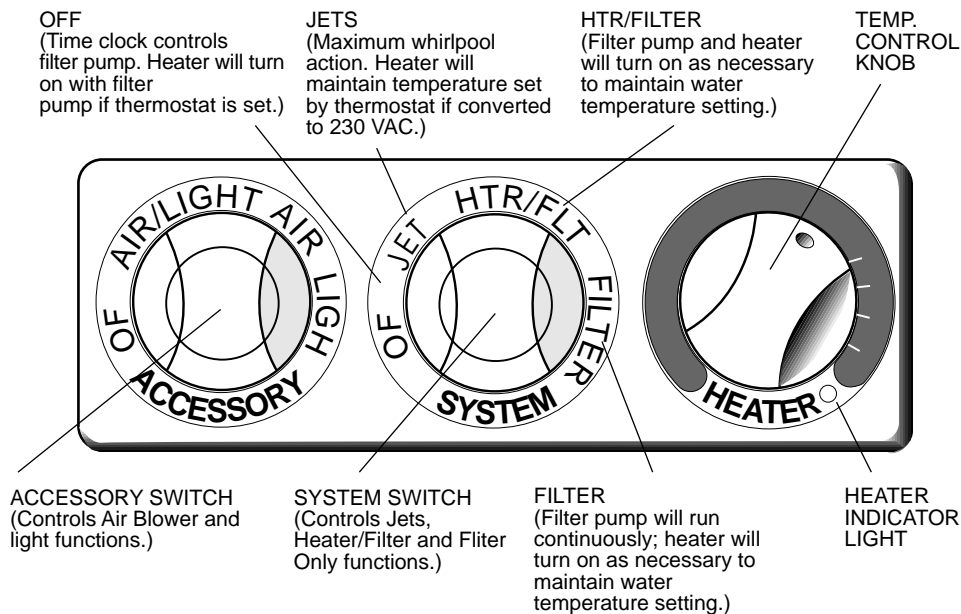

OPERATION

Temperature Control

Turn on the heater by selecting the HTR/FLTR mode with the SYSTEM switch.

With this selection, you can verify that the spa's heater is operating by viewing the indicator light on the spa control panel.

Set the HEATER knob by rotating it to the desired temperature. When the water temperature is lower than that set by the HEATER knob, the heater and filter motor/pump will be activated. The heater and filter functions will automatically turn off when the desired temperature is reached. When the heater is on, the water is also being filtered. The heater will also maintain water temperature in the JETS mode. The heater control is designed to maintain a minimum temperature of approximately 45-50°F, its lowest setting. This does not necessarily protect the spa from freezing.

Setting the Thermostat

When your spa is plugged in and HTR/FLTR has been selected on the control panel, your heater thermostat is working to maintain the temperature to which you have set the HEATER knob. You will notice by the indicator light that the heater is on when the water temperature falls below the desired temperature and will turn off when that temperature has been reached.

When the spa is not in use, you can set the thermostat to a lower temperature; then, when you wish to use the spa, adjust the HEATER knob to the desired temperature. The water temperature will rise at a rate of about 2° per hour with the optional spa cover, foam insulation and skirt panels in place and if the air temperature is 50° or warmer. This rate will necessitate a waiting period before using the spa, the length of which will be determined by the temperature of the water before turning on the heater. For example, if the water in the spa is kept at about 70° when the spa is not in use, and the desired temperature is 100° , it will take about 5 hours to heat up sufficiently.

Once you have determined the desired setting on the thermostat knob, it is not necessary to change or re-adjust it again during normal operation unless you decide on a different setting.

The optional spa cover available for your spa will help control heat loss from the water surface and thereby reduce energy consumption. You can improve the spa's heat retention by keeping the spa cover in place on the spa while heating the water.

Note on Determining Water Temperature:

As spa products generally perform in a narrow range of operating temperatures, we recommend that you use a medical (clinical) type thermometer for an accurate measurement of spa water temperature. Other types of thermometers, generally available, such as

those used for swimming pools, are not sufficiently accurate to determine spa water temperatures. Take water temperature readings in the HTR/FLTR mode when the heater has just turned off; the indicator lamp on the control panel will turn off at this time.

Setting the Timer

The built-in 7-day timer is located in the System Control Module. The tooth-like tabs that are located on the dial can be set to activate the filter system for two-hour periods on any day(s) of the week. First set the correct time. Set the time of day by rotating the outer dial and aligning the correct time with the small arrow in the inside of the dial. Note: Both correct time and day must be set. Next slide one of the tabs toward the center of the dial at the time at which you wish the filter system to operate. Note that the timed mode can begin at any time of day or night on any specified day of the week.

TIMER

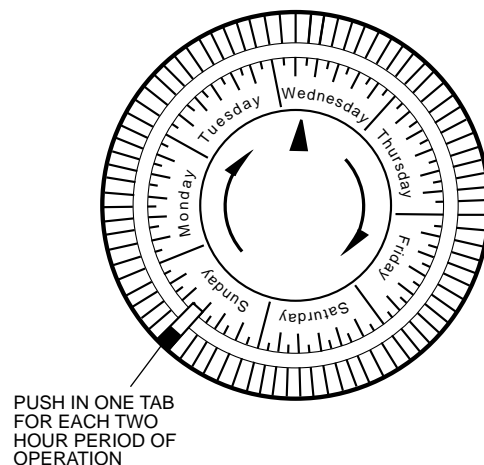

230 Volt Operation

If your spa has been converted to 4-wire, 230 Volt, 50 AM P, there are a few difference in operation. First, all features are operational and there are no overriding functions. Additionally, after converting to 230 V, the spa's heating time be approximately 8° per hour instead of 2°.

Finally, whenever you need to perform maintenance on the spa, or when you need to drain the spa to below its normal operating level, make sure power to the spa is turned off at the house service panel, as there will be no power cord to unplug.

OPERATION

Normal Operation

Whirlpool System:

You can enjoy the Palio spa with or without activating the whirlpool. Either way, bathing in your spa can be pleasurable, as well as therapeutic.

For an invigorating spa experience, you can take advantage of the built-in whirlpool system. To do this, push the SYSTEM switch button to select the JETS mode. Sit or recline in the spa so you are comfortable. The fully adjustable whirlpool jet located on the wall opposite the control panel can be adjusted to control the force of the water coming into the spa. For stimulating action, increase the force of the flow by rotating the jet handle to the left. For a more relaxing effect, rotate the handle to the right (clockwise). The directionally adjustable whirlpool jets can be directed toward any location on the body, particularly toward any area that feels tense or stiff. The warmth of the water and the stimulating water flow from the jet will pleasantly increase circulation.

Or, for the total whirlpool effect and all-over feeling of well-being, you can adjust all jets so they point in a clockwise or counter-clockwise direction to circulate the air and water mixture in a circular motion all about the spa.

Note: For maximum whirlpool jet flow, rotate the Water Rainbow flow control handle upward to turn off the flow through the spout.

FULLY ADJUSTABLE WHIRLPOOL JET

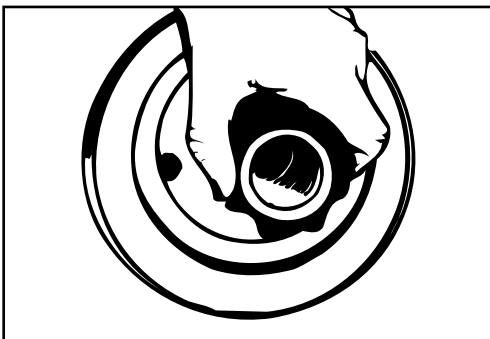

Silent Air Induction

The intensity of the whirlpool action is determined by how much air is inducted into the water. You have control of this by adjusting the air induction control knobs located on both control panels. For maximum air induction, rotate each control knob fully counter clockwise to the largest circle. For fewer air bubbles, decrease the amount of air induction by rotating the control knobs clockwise. When the knobs are turned to the smallest circles, only water is being circulated.

Water Rainbow™ Spout

The Water Rainbow spout will add the soothing sound of a waterfall to your bathing pleasure, as well as provide beautiful cascades of shimmering water for an exciting visual effect.

Activate the waterfall feature by first turning on the JETS, HTR/FLTR, or FILTER function, then rotate downward the flow control lever located on the left side of the spout. Use this lever to adjust the amount of water flowing through the Water Rainbow spout. The waterfall effect will be greatest in the JETS mode. Turning off the flow at the fully adjustable jet will dramatically increase Water Rainbow flow.

CAUTION: The water circulating through the Water Rainbow spout is not fresh water and therefore is not suitable for drinking.

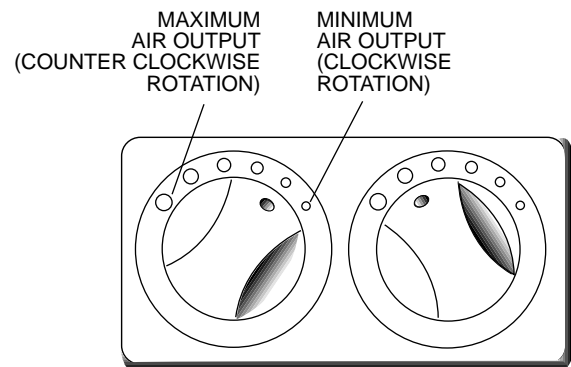

Air Blower

The Palio features a built-in air blower and factory drilled air holes in the seats of the spa to add to your enjoyment.

The blower sends air to a channel located under the spa's seats; this air is distributed through the air holes, forming tiny bubbles which travel upward until they reach the surface and burst. The exciting visual effect of the bursting bubbles contributes to the overall hydro-massage experience.

Activate the blower by pushing the ACCESSORY switch. (Note that when the blower is on, the low speed of the motor turns on to activate the pump which allows filtration of the water and use of the Water Rainbow feature. However, while the blower is operating (in the 115V system), neither the jets nor the heater will function, If the heater mode has been selected, the heater will come on again automatically when the blower is turned off.)

Filtration

When you are ready to leave the spa, push the SYSTEM switch button to turn off the whirlpool.

MAINTENANCE

Then select the HTR/FILTER mode. Adjust the HEATER knob to the temperature at which you wish the water maintained. In this way, the water will be filtered when the heater goes on to maintain the temperature. Whenever the water temperature reaches the desired temperature, the pump will turn off.

Another way to be sure the water will be filtered

is to turn the SYSTEM off and set the built-in timer in the System Control Module to turn the system on at a certain time to filter the water. Be sure there is sufficient water in the spa (filled to the water line indicator mark on the skimmer/filter frame) when the timer is set, or the spa's motor/pump could be damaged. (See page 8 for instructions on setting the timer.)

Water Quality and Water Chemistry

Maintaining water quality and water chemistry in your spa is extremely important and should be a regular part of your spa maintenance program, as a neglected spa can be a breeding place for dangerous bacteria.

The water quality of your spa is maintained by a combination of filtration and chemistry. The spa's integral filter system helps maintain the water cleanliness and clarity by trapping most solid materials such as body oils, hair, and other debris resulting from normal use. However, the most important part of maintaining water chemistry is keeping the proper level of disinfectant in the water at all times. This is accomplished by adding chlorine or bromine (but never mix the two!) to the water, which will control particles too small to be trapped by the filter, such as bacteria and algae, and will oxidize any organic materials. Follow instructions provided here and with water quality products for the health and safety of spa users, as well as to make your spa bathing as enjoyable as possible.

Filtration

The filtration system of your spa will keep your water clear and clean if used properly. We recommend that you run your filter system for at least two hours each day. The filter cartridge elements will trap most solid materials and debris in the water. However, the presence of materials such as body oils or other particles which are too small to be captured in the filters may bring about various undesirable water quality conditions. These conditions can be corrected with the use of spa treatment chemicals which are available from your Jacuzzi Whirlpool Bath dealer. Such conditions include the following:

Foaming: A defoamer is available to minimize foaming of the water. This condition is usually caused by the addition of soaps or oils, or other fatty substances to the spa water. The interaction of these with hot water, especially at high pH (more alkali), will cause the water to foam. (See Water Quality Definitions.)

Oil Film or Cloudy Water: Add clarifier to congeal oil film on the water surface into globules sufficiently large to be trapped by the system's filter. Cloudiness is caused by particles that are too small to be trapped in the filter, and is also due to the presence of human body oils, lotions, and cosmetics. During normal use, these materials can accumulate on the filter element and clog its pores. The addition of clarifier will make the water clearer, but clogged filters must be cleaned as prescribed under the section entitled "Filter Maintenance" in this manual.

Hard Water: Add a de-mineralizer to break down or de-ionize mineral particles present in the spa water.

Follow the "Filter Maintenance" procedure described in this manual to ensure optimum performance of your spa's filtration system.

Water Chemistry

You can ensure better water chemistry by testing your spa water every day and adjusting the chemical balance frequently. Obtain a water quality test kit, designed especially for spas, from your Jacuzzi Whirlpool Bath dealer. The test kit must be of the type which allows you to test for the disinfectant (chlorine) level, pH, and total alkalinity. Make sure, also, that chemicals used in your spa are especially for spa use, and not for swimming pools, as water quality maintenance of spas and swimming pools is very different.

Set up a daily program at first to check the disinfectant level, pH, and total alkalinity of the water to familiarize yourself with the amount of chemicals to add and to determine how often to make chemical adjustments during normal use. Remember that the more heavily the spa is used, the more often you should check the water chemistry.

When adding any chemicals, always run the filter system to ensure complete dilution with the water. **Do not add chemicals directly into the skimmer opening.**

Water Chemistry (Continues, next page)

MAINTENANCE

Water Chemistry (continued)

Disinfecting:

When filling the spa for the first time, follow the purge/sanitizing instructions in the Equipment Set-Up procedure of the Installation Instructions.

Add a disinfectant to the water on a regular basis to help control the amount of bacteria, algae and organic materials. Such bacterial contaminants, if not controlled, could cause skin rashes or other physical problems. To disinfect the spa for normal use, first establish the amount of chlorine or bromine to add and determine how often you need to add it.

We recommend that you maintain a free chlorine level of 2.0 - 5.0 ppm at all times except when you must exceed that during the initial purge/sanitizing procedure or during superchlorination (see "Water Quality Definitions" below). Superchlorinate your spa every two weeks with heavy use. If using sodium dichlor, add one heaping tablespoon for each 150 gallons of spa water. Scrub the spa surfaces with this solution to remove any oily deposits. This will ensure that any bacteria or algae which are resistant to the normal disinfectant level are killed. After adding the disinfectant, run the filter system and allow the free chlorine level to return to the 2.0 to 5.0 ppm range before using the spa again. Do not install a rigid cover during this procedure until the disinfectant level is back to normal. High concentrations of chlorine or bromine will damage spa fitting finishes if the cover is in place.

Balancing pH:

For good hygiene and equipment longevity, maintain the pH of your spa water according to the instructions provided. pH is the measure to determine if the spa water is too acid (low pH) or too alkaline or basic (high pH). The ideal range for spa water is 7.2 to 7.6 pH. For excessive acidity (below 7.2 pH) add soda ash or sodium bicarbonate to the spa water. For excessive alkalinity (above 7.6 pH) add dry acid to the spa water. Caution: Refer to the spa chemical manufacturer's instructions for the initial amount of chemicals to add for the gallonage of your spa. Low pH can cause equipment damage, as acid water will dissolve metals, while high pH can cause scale or calcium deposits to build up in the system or on the shell. After adding chemicals, run the filter system for at least 30 minutes before testing water quality again for accurate readings.

Balancing Total Alkalinity:

Total alkalinity is the measure of base materials in the water. The recommended range for total alkalinity is between 80 ppm and 150 ppm. If the chemistry of the water is not within this range, you will have difficulty adjusting your pH level, which will affect your adjustments for the proper amount of free available chlorine. If the alkalinity of your spa water is high, it is advisable to drain the water from the spa and begin the balancing process over again. Purge and sanitize your spa (according to instructions in Equipment Set-Up section of the Installation Instructions) and clean the spa surfaces thoroughly before refilling with fresh water. Then re-establish water chemistry. If the spa is used heavily, change the water at least every month.

WATER QUALITY DEFINITIONS

pH: A chemical term used in expressing relative acidity or alkalinity in numeric values with 7.0 usually regarded as neutral, and for purposes of this manual, indicating pure water. From 7 to 0 indicates increasing acidity, and 7 to 14 indicates alkalinity.

PPM: Parts per million.

Free Chlorine: Chlorine that has not combined with other chemicals and that is available to destroy bacteria in the spa water.

TriChlor: A form of chlorine used in pool or spa water treatment; usually supplied in tablet form. Not recommended because of its higher acidic nature and slow dissolving action. Prolonged contact with the spa shell may bleach or permanently mark the shell.

Sodium DiChlor: The type of chlorine that is recommended for spa use, as it is available in fast dissolving granular form. It is neither excessively acid nor alkaline in character and does not readily dissipate in higher water temperatures.

Calcium Hypochlorite: A granular chlorine product that is inexpensive and effective but not recommended because it

often tends to form calcium deposits on heater parts and plumbing fittings and leaves an unattractive film on the spa at the water line.

Sodium Hypochlorite: A liquid chlorine product that is inexpensive and effective but not recommended because the liquid is readily spilled onto the spa or a surrounding area, causing permanent damage.

Total Alkalinity: The measure of amount of alkaline materials (such as carbonates, bicarbonates and hydroxides) in the water. High alkalinity inhibits the effectiveness of chemicals to change the pH. If the alkalinity of your spa water is high (above 150 ppm), it is advisable to drain the water from the spa and begin the balancing process over again. Low total alkalinity (below 60 ppm) could be corrosive and damage your spa system.

Superchlorination: (also referred to as "shock treatment") The addition of an above-normal level of disinfectant to kill any bacteria or algae that might have become resistant to normal levels of disinfectant.

MAINTENANCE

Water Level/Drain

The water level in the spa must be maintained at its normal level. Evaporation and splashing will cause the water level to drop.

When concentrations of impurities from evaporation, water quality chemicals, body oils, perfumes, dirty feet, and winds, etc., accumulate in the spa and cannot be filtered out, it is necessary to drain your spa and refill it with fresh water. This should be done every 2 months or more often depending on the amount of use.

To drain the spa, turn all controls to OFF, then turn off circuit breakers at the main electrical panel. Connect a garden hose to the hose bibb in the suction plumbing. Turn the handle and drain the spa.

After draining the spa, clean the spa shell, suction covers, skimmer, and filter, then close the hose bibb and refill the spa with fresh water. Check the pH level and maintain water quality.

NORMAL WATER LEVEL

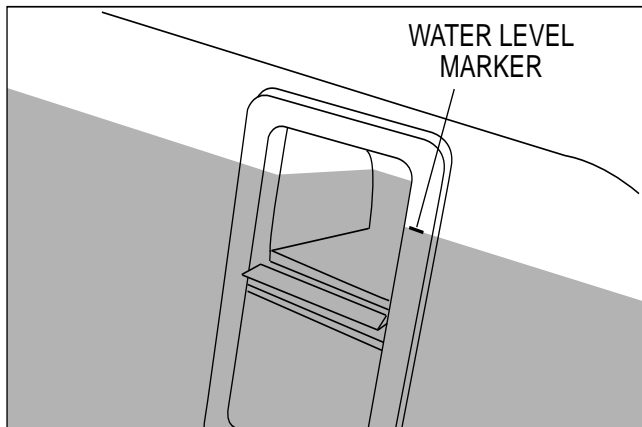

The suction covers located in the foot well area should be checked at least once a week for collected debris, such as leaves, hair, etc., and cleaned as necessary. It may not be necessary to remove the suction cover to clean it, but if you need to, remove the center screw with a Phillips type screwdriver and clean the cover by flushing with water from a hose.

CAUTION: Be sure to replace the suction cover immediately after cleaning. It is a safety device and must be in place over the suction fitting to minimize potential hazard of hair and body entrapment.

If heavy rains raise the spa water level, drain the spa to its normal level.

A rigid spa cover (available as an option), when in place over the spa, will help reduce evaporation and control the amount of debris entering the spa when the spa is not occupied. In addition, its use will reduce energy consumption.

Skimmer Basket Maintenance

The basket located in the skimmer of the spa should be checked at least once a week for collection of debris, such as leaves, hair, etc., and cleaned as necessary. To clean the basket, remove it from the skimmer by pulling it out, then backflush it with a garden hose and reinstall.

FRONT ACCESS SKIMMER/FILTER

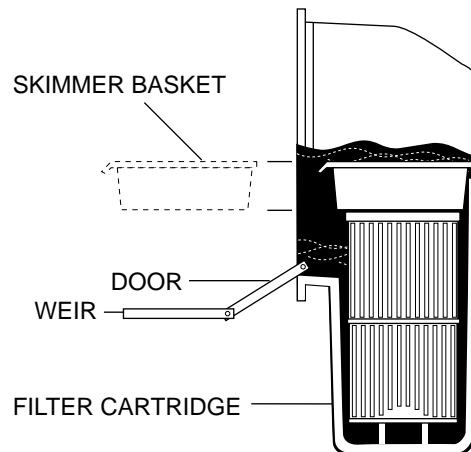

Filter Maintenance

The filter should be checked periodically. In normal use, check the filter at least once a month. Keep the filter clean; an obstructed filter reduces water quality and inhibits proper system performance.

A removable filter cartridge is located inside the skimmer. To remove it, pull open the skimmer door by the handle located in the middle of the door. Slide the basket out, then pull the filter cartridge upward and out of the housing by the loop at the top of the filter. Clean the filter by separating the folds of the filter and spraying with fresh water from a garden hose. Then reinstall the cartridge in the housing and replace the basket, reversing the above procedure.

Oils will coat the filter, resulting in a reduced flow. To remove such materials, soak the cartridge in a plastic pail containing a commercial filter cleaning solution (available from your Jacuzzi Whirlpool Bath dealer or most pool supply stores). Follow the manufacturer's instructions for use. Another method is to soak the filter cartridge in a plastic pail containing a mild solution of trisodium phosphate (TSP) and water. An hour of soaking time is usually required to break down oil coatings from the cartridge. Use a stronger solution of TSP and water to remove algae. Most hardware or paint stores stock TSP. Use the same method of cleaning when the cartridge becomes plugged with clay or vegetation.

MAINTENANCE

Automatic Filtration/Maintenance

If you plan to be away, you should maintain minimum water quality by running the filter system. To do this, set the timer to turn the system on for at least two hours each day. This will cause the filter system to turn on at a desired time. Set the timer according to instructions on page 8 with the SYSTEM switch turned to OFF. If you do not want the water to be heated, turn the HEATER CONTROL knob to its minimum setting.

If you will be away for an extended period, however, we recommend that you drain the spa (following the procedure described under Winterizing on this page), as long periods without maintenance of water quality could be detrimental to the spa.

Another means of maintaining minimum water quality while away for less than two weeks is to follow the procedure outlined for winterizing your spa in a warm climate. (See Winterizing.) Note: We do not recommend using this procedure if you are absent during the summer, when algae build-up is most likely.

Always keep your spa covered when not in use to reduce heat loss and evaporation and to prevent debris from falling in.

Winterizing

In a climate where winter temperatures are below freezing, follow this procedure when the spa will NOT be used:

1. Select the OFF mode.
2. Turn off power to the unit at the house circuit breaker.
3. Drain the spa completely by attaching a garden hose to the hose bibb on the suction plumbing. Then remove the hose and leave the hose bibb open to completely drain the spa. Close the hose bibb.
4. Remove the lowest 1/8" plug from the face of each pump housing, then replace the plug after all water has drained out. (See figures A and B.)
5. Remove the filter cartridge, clean it, and store it dry.
6. Keep water and debris out by covering with a rigid spa cover.
7. Before using the spa again, review the Operating Instructions.

CAUTION: Not winterizing will cause irreversible damage (at freezing temperatures) to the pump and/or plumbing lines.

Note: If the spa is to be used during winter in a cold climate, see warm climate instructions below.

In a warm climate where there are occasional freezing temperatures, follow this procedure:

1. Select the HTR/FLTR mode.
2. Set the thermostat to its minimum temperature (45-50°F.) by turning the HEATER KNOB all the way counter-clockwise.
3. Maintain a chemical balance. (See Water Quality section.)
4. Keep the spa covered.

INTERIOR LOCATION OF AIR BLOWING PIPE DRAIN PLUG

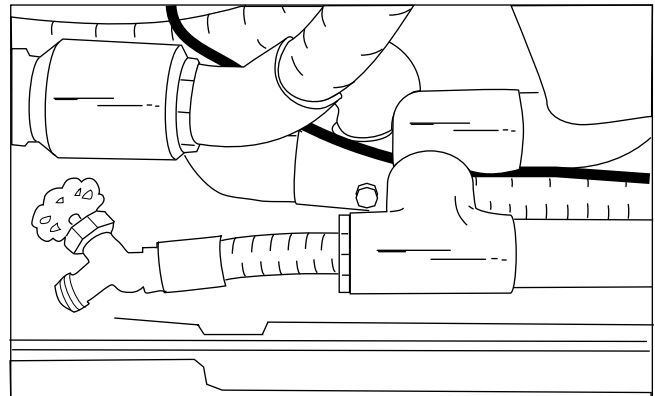

AIR BLOWER PIPING
DRAIN PLUG

Factory Installed Redwood Skirt

Your Palio™ spa is supplied with a factory-installed redwood skirt which completely surrounds the spa. The door can be opened for routine maintenance, setting the timer, and for testing the GFCI before use.

The skirt is made of kiln-dried redwood and can be left natural to weather, or you may choose to apply a stain or clear finish. Consult your local paint dealer for the appropriate product.

It may become necessary to remove one or more of the skirt panels for major service access, **but all the panels must be securely in place during use of the spa.**

To detach any of the panels, first remove all screws from the panel being detached.

The panels can be re-attached to the spa by reversing the above procedure.

MAINTENANCE

Redwood Skirt Install, (Con't)

Note: When you remove the skirts, you will notice the plastic covered, foam insulation blocks. These blocks are designed to be removed, then re-installed when service has been completed.

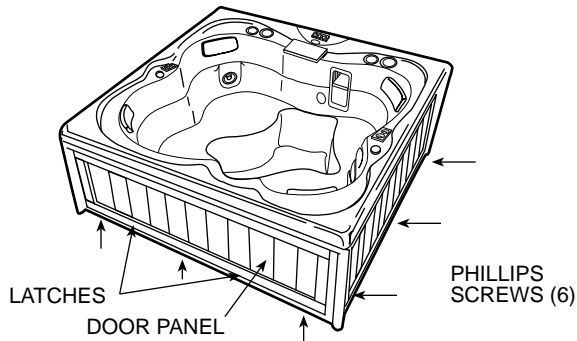

Spa Light

Two colored filters are provided with your spa. To change the filter, simply pull the filter out of the fitting and replace it with the desired colored filter. Two replacement bulbs (#912) are also included. Put them in a safe place for future use. When a bulb burns out, replace it from the **back** of the light fitting, pulling out the bulb receptacle.

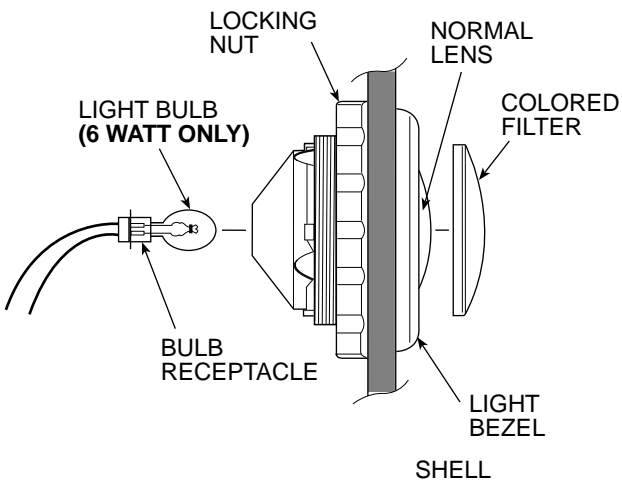

Cleaning Your Spa

Your Palio spa shell consists of two layers of plastic materials. Its smooth top surface of acrylic is tough and durable and contains concentrated color. This is supported by a substantial thickness of fiberglass-reinforced polyester resin. A catalyst causes a chemical reaction during manufacture that bonds these layers permanently into a hard, strong material. With a minimum amount of care and cleaning, your whirlpool spa will look new for years.

To clean your spa, simply use a mild, non-abrasive liquid detergent, isopropyl alcohol, or commercially prepared spa cleaner. **Do not use abrasive cleaners.** You can protect and restore the gloss to a dulled surface by applying Meguiar's #10 Mirror Glaze, which is a product

specifically designed for use on acrylic finishes. If Meguiar's is not available, an acrylic polish of equal quality or automotive paste wax will do.

Use a spa cleaner for residue buildup at the water level of the spa surface. This may be applied to the acrylic surface with a soft cloth and wiped clean. Use sparingly in small amounts to avoid contaminating the spa water. If heavily soiled, it may be advisable to lower the water level 2-3 inches before cleaning; then refill to normal level.

Covering Your Spa

An optional rigid spa cover is available to place on top of your Palio Spa from your Jacuzzi Whirlpool Bath dealer. Use of this cover will help to minimize heat loss and evaporation, and thus reduce energy costs. The cover is also an attractive and efficient means of preventing debris such as leaves and dirt from entering your spa when not in use. Follow the instructions for use and care provided with the spa cover.

CAUTION

While the spa cover is rigid, it is not designed to support any weight. Therefore, as a safety precaution and to preserve the life of your cover, you must not sit, stand, or lie on it; nor should you place objects of any kind on top of it.

Jacuzzi Whirlpool Bath does not guarantee or warrant this cover. Refer to spa cover manufacturer's information provided with the cover.

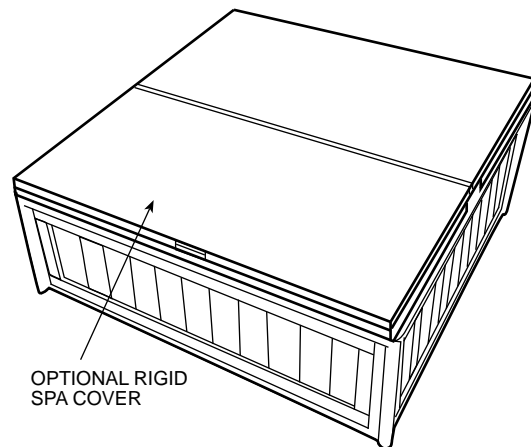

Repairs to the Acrylic

Minor scratches which do not penetrate the color finish (acrylic) can be removed with 600-grit wet/dry sandpaper. Restore the glossy finish with Meguiar's #10 Mirror Glaze or comparable automotive paste wax.

Major scratches or gouges which penetrate the acrylic surface will require refinishing. Ask your Jacuzzi Whirlpool Bath dealer for special instructions.

TROUBLESHOOTING GUIDE

CAUTION: Opening the System Control Module door voids the warranty. This equipment requires qualified service personnel for proper repair. Contact your Jacuzzi Whirlpool Bath dealer for service.

PROBLEM	PROBABLE CAUSE	
1. Control Switches do not respond.	<ul style="list-style-type: none"> A. No power to the unit. B. Actuated too rapidly. C. Switch tubes disconnected D. Safety switches tripped. E. System malfunction. F. Motor not connected. G. Faulty pump or motor. 	<ul style="list-style-type: none"> A. Turn on house circuit breakers; be sure unit is plugged in. B. Wait 60 seconds; system will be restored automatically. C. Check yellow and orange labeled air tube connections at base of SCM. D. Reset GFCI and circuit breakers, temperature switch on heater (water temp. must be less than 100°F; close access door.) E. * F. Check motor plug connection on SCM. G. *
2. Heater not functioning.	<ul style="list-style-type: none"> A. Heater mode not selected. B. No power to heater. C. Thermostat set lower than water temperature. D. Heater plug loose. E. Flow switch not operating or plug loose. G. Abnormally low water flow. H. System malfunction. 	<ul style="list-style-type: none"> A. Select HTR/FLTR mode. B. Check power cord and GFCI. C. Turn thermostat to desired temperature. D. Check heater plug connection on SCM. E. Check flow switch plug connection on SCM. G. Add water. H. *
3. Heater not functioning, but heater light on.	<ul style="list-style-type: none"> A. Heater plug loose. B. Relay malfunction. 	<ul style="list-style-type: none"> A. Check heater plug connection on SCM. B. *
4. Low water flow from jets.	<ul style="list-style-type: none"> A. Normal operation in FILTER Mode or when Water Rainbow open. B. Low water level. C. Clogged or blocked suction strainer or skimmer basket. D. Dirty filter. E. Plumbing shut-off valve not fully open. F. Air induction system turned down. 	<ul style="list-style-type: none"> A. Select JETS mode for maximum flow. B. Fill to water level indicator on skimmer/filter. C. Clean strainer or basket. D. Clean or replace filter. E. Check and open plumbing valve. F. Turn air induction knobs fully open.

***Note:** The skills and tools necessary for the safe repair of this spa require the services of qualified service personnel. Contact your Jacuzzi Whirlpool Bath dealer.

TROUBLESHOOTING GUIDE

PROBLEM	PROBABLE CAUSE	REMEDY
5. Motor stops or will not operate.	A. Thermostat satisfied in HTR/FLTR mode. B. Motor overload condition. C. Inadequate electrical supply to spa. D. Spa circuit protector tripped. E. System malfunction.	A. Select FLTR or JETS mode. B. Turn off motor and let cool for 1 hr. If problem persists, see *Note. C. Try test on p. 15; then consult electrician to provide proper service. D. Reset circuit protector on SCM. E. *
6. Air blower does not operate.	A. ACCESSORY switch not in AIR mode. B. Blower plug loose. C. Blower disconnected from plumbing. D. System malfunction E. Spa circuit protector tripped.	A. Sequence ACCESSORY switch. B. Check blower plug on SCM. C. Check that blower is connected and clamps are secure. D. Call for Service. E. Reset circuit protector on System Control Module.
7. Noisy motor/pump.	A. Clogged strainer or skimmer basket. B. Low water level. C. Loose parts attached to motor support brackets. D. Leakage of air into suction line. E. Damaged or worn motor bearings. F. Impeller rubbing inside case. G. Debris inside pump. I. Plumbing shut-off valve not fully open.	A. Clean strainer(s). B. Fill spa to normal level. C. Tighten fastener. D. Check for leaks; tighten clamps and flange bolts. E. Locate and repair leaks. F. * G. * I. Open Valve.
8. Water leakage at pump shaft (rotating connection between pump and motor.)	A. Worn or damaged pump seal.	A. *

***Note:** The skills and tools necessary for the safe repair of this spa require the services of qualified service personnel. Contact your Jacuzzi Whirlpool Bath dealer.

TROUBLESHOOTING GUIDE

PROBLEM	PROBABLE CAUSE	REMEDY
9. Water not clean.	<ul style="list-style-type: none">A. Clogged or blocked suction strainer or skimmer basket.B. Filter clogged (dirty).C. Poor water chemistry.D. Insufficient filtering.E. Improper maintenance. F. High content of solids in water.G. Filter motor plug not connected.H. Shut-off valve closed.I. Mixing two chemicals when adding to spa water.	<ul style="list-style-type: none">A. Clean strainer/skimmer.B. Clean or replace.C. See "Chemistry" section (p11).D. Increase daily filtering time.E. See "Maintenance" section (pgs 11-15).F. Use clarifier or drain and refill spa.G. Check filter motor connection on SCM.H. Check and Open valve.I. Add chemicals one at a time; allow a few minutes between adding to spa water.

***Note:** The skills and tools necessary for the safe repair of this spa require the service of qualified service personnel. Contact your Jacuzzi Whirlpool Bath dealer.

IMPORTANT

The Palio Portable Whirlpool Spa requires a 115 VAC 20 AMP capacity electrical supply. If the wiring of the circuit in which your spa is connected is not sized properly for 20 AMPs, or if the outlet used is too distant from the main service panel, there may be a considerable voltage drop. Such a voltage drop would not only cause the unit to malfunction, but it may also cause permanent damage to the spa's electrical system.

Before operating you spa, therefore, we recommend that you test the spa's intended electrical supply circuit for sufficient voltage. To do this, you will need an AC voltage meter and a small electrical appliance rated at 1200 (min.) - 1600 (max.) watts, such as a toaster or small heater. With the appliance turned off, plug it into the receptacle and take a voltage meter reading from the adjacent receptacle. Next turn on the appliance to its maximum setting and again measure the voltage as before. The difference between the two voltage readings must not be more than 5%. For example, if the "OFF" voltage is 115, the "ON" voltage must not be below 109. If there is a voltage drop of more than 5% or if there is less than the 105 V minimum operating voltage at the receptacle, the electrical supply is insufficient. The minimum voltage must be maintained during spa operation.

If your test reveals insufficient electrical supply, several solutions are possible; First, you could have your electrical supply upgraded and provide a dedicated, properly wired circuit with 20 AMP capability to be used for the spa only. Second, you can install a transformer which would boost your existing power supply. We recommend that you seek the advice and services of a qualified electrician who can determine your particular electrical needs for installation of your spa.

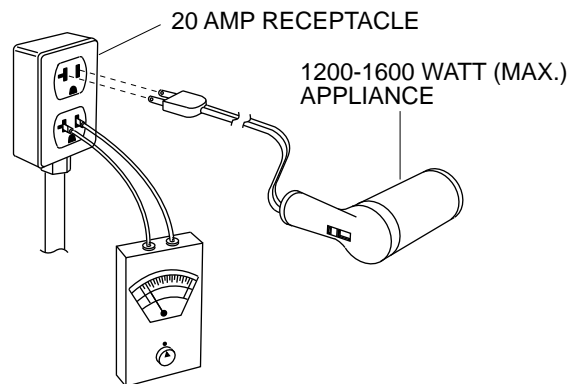

Alternate Use of Water Rainbow™ Spout as Fill Spout

You can use your Water Rainbow spout as a fill spout by permanently plumbing it to a fresh water supply if local codes permit. Local plumbing codes may require the use of an anti-siphon valve for such a connection. **Do not interconnect water supply with recirculating system of the spa.**

To make the connections necessary to use the Water Rainbow as a fill spout, follow this procedure:

- Make sure spa is unplugged and completely drained.
- Cut the 3/4" flex pipe which connects the Water Rainbow spout to the discharge system.
- Unscrew the cut pipe and fitting from the spout.
- Cap off the piping by cementing a 3/4" PVC cap where cut has been made (Cap not provided.)
- Connect permanent plumbing line to the spout.

SUGGESTED MODIFICATION (REFER TO LOCAL CODES FOR REQUIREMENTS)

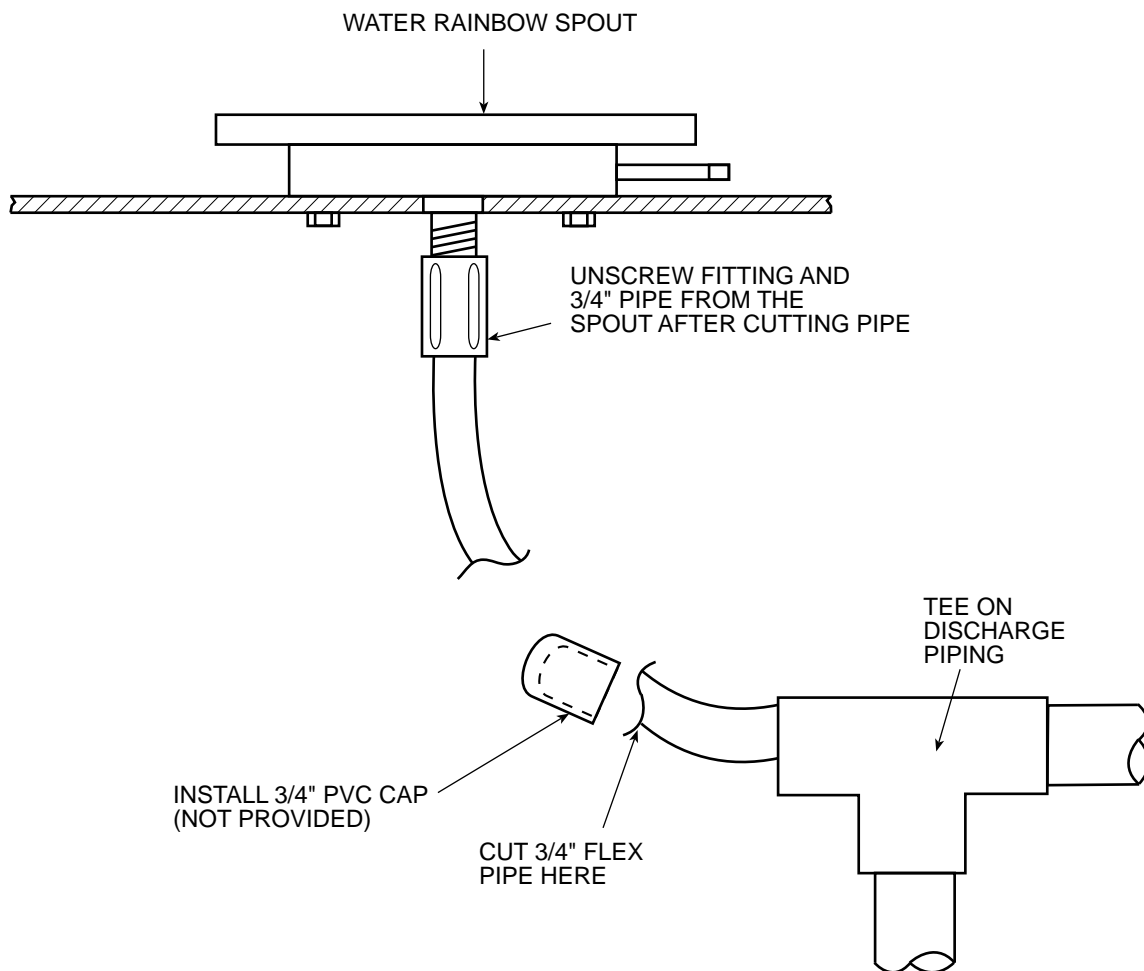

**PRODUCT SPECIFICATIONS ARE SUBJECT TO CHANGE WITHOUT NOTICE.
USE INSTALLATION INSTRUCTIONS SUPPLIED WITH PRODUCT.**

Jacuzzi Whirlpool Bath has obtained applicable code (standards) listings generally available on a national basis for products of this type. It is the responsibility of the installer/owner to determine specific local code compliance prior to installation of the product. Jacuzzi Whirlpool Bath makes no representation or warranty regarding, and will not be responsible for any code compliance.

JACUZZI WHIRLPOOL BATH

Jacuzzi Whirlpool Bath National Headquarters
P.O. Drawer J, Walnut Creek, CA 94596 1-(510) 938-7070
Customer Service: Call 1-(510) 938-7411, or 1-(510)-938-7070

